

MY GRACE - Specification



MAIN DESCRIPTION

Builder: Amels. Netherlands
Built: 2009
Length: 52,3m
Beam: 9,5m
Draft: 3,3m
Hull material: Steel
Engines: 2 MTU 16V2000 M70
Range: 4500 Nm @12 Kn
Top speed 15 kn

Accommodation

Guests: 12 (12 sleeping)
Crew: 12
Price: 23,000,000 EUR
Location: Monaco

MY GRACE - Specification

MAIN CHARACTERISTICS

Type:	Displacement mono hull motor yacht
Builder:	Amels
Year:	Delivered - 2009 / keel laid – 2007
LOA:	52,3 m
LWL:	46,9 m
Beam:	9,50 m
Draft:	3,30 m
GT:	642 tons
Flag:	Cayman Islands
Class:	Lloyds Register A1 Class Yachts Mono
Exterior Design:	Tim Heywood Designs
Interior Design:	Laura Sessa Romboli
Hull:	Steel
Superstructure:	Aluminium
Cruising Speed:	12 kn
Max Speed:	15,5 kn
Range:	4500 Nm @ 12 Kn
Total guests (sleeping):	12
Total guests (cruising):	12
Cabins:	6
Crew:	12
Number of Beds - Crew:	14
Bed Configuration - Crew:	Double

CAPACITIES

Fuel	117000Litres
Fuel consumption	400 l/hr at 12 kn
Fresh Water	16000 Litres
Bow Thruster	Electrical Jastrum
Tender Fueling	80 Litres
Bilges	5000 Litres
Sewage Treatment	3000 Litres
Exhaust	Wet

MY GRACE - Specification

MECHANICAL EQUIPMENTS

Engine	2 MTU 16V 2000M 70
Hours (approx.)	5358 h (Port side) 5355 h (Starboard side)
Generators	Northern Lights
Hours (approx.)	6055 h (Port side) 6028 h (Starboard side)
Air conditioning	Hemen Hofman
Stabilizers at anchor	Zero speed VT Naiad Marine System
Stabilizers underway	Zero speed VT Naiad Marine System

TENDER & TOYS

- PASCOE Rescue Tender 6.2m
- x2 Sea-Doo Wave runner Jet-Ski
- x2 Yamaha Stand Up Jet-Ski

All hours are up to date as of 16th Nov 2018 - more accurate information on request

AUDIO VISUAL EQUIPMENT

- LANTIC System throughout
- McIntosh - full audio system
- Projector - Cinema set up

COMMUNICATION

- V SAT

ACCOMODATION

GRACE boasts six versatile en-suite staterooms: 2 cabins on the main deck, including Master cabin and four cabins on the lower deck

ADDITIONAL INFORMATION

- Regular winter maintenance & re-fit of all parts and items required to preserve her standard since her launch
- Full re-spray in 2016

MY GRACE - Specification

DESCRIPTION

Delivered in 2009 by Amels shipyard, GRACE is a 52,30m (171') superyacht from the Amels Limited Editions series with an exterior design from Tim Heywood that has been the world's best-selling 55-metre superyacht since 2007. The full displacement hull and her large volume of 649 GT provide high comfort with ocean-going performance to discover destinations all over the world, together with a modern classic design. GRACE was never available for charter, she is offered in pristine condition for the very first time on the brokerage market.

Her wide outdoor spaces are among the major specificities of GRACE and the Amels 171 Limited Editions in general. From the generous swim platform and garage to the Main deck aft with a large lounge seating area with exterior sets done by Summit and custom made furniture by Metrica, your first steps on board already give the tone of her perfect quality. The Bridge deck aft offers another option with lounge, dining area for 10 guests (custom made design), the crane can be used to place tenders from Fore deck to Bridge deck aft during potential Atlantic crossings. Going up to the panoramic Sun deck with Jacuzzi, bar and an extra option for al-fresco dinners with a table for 10 persons.

GRACE's interior is designed by Nuvolari Lenard studio: rich dark colours reflected by wengé wood and dark leather, and the light colours are shown by white oak, alcantara fabric and light capria leather. Accents are given by a high gloss varnish on the wood. Custom made fittings provide distinguished and original detailing throughout the interior. Starting from the Main deck salon with lounge , table for 8 guests and TV MD Salon does not have a TV only in BD salon with Crestron system included throughout the vessel, the cosy area continues up to the full-width Bridge deck salon fitted with projector and cinema screen from ceiling. GRACE also includes a layout with six cabins, comprising of a full-width en-suite Master with large bathroom, dressing, fully operational office and swivel TV, and a double en-suite Guest cabin on Main deck; plus four Guests cabins on Lower deck: 2 Double cabins on starboard side, all en-suite, and 2 Twin cabins on port side. The aft cabins are interconnecting connecting with the port side Double cabin, an ideal compromise for guests with children.

Including a large set of watersports and cruised by an experienced crew of 13, GRACE is one superyacht not to be missed!

MY GRACE - Specification

DECK PLANS

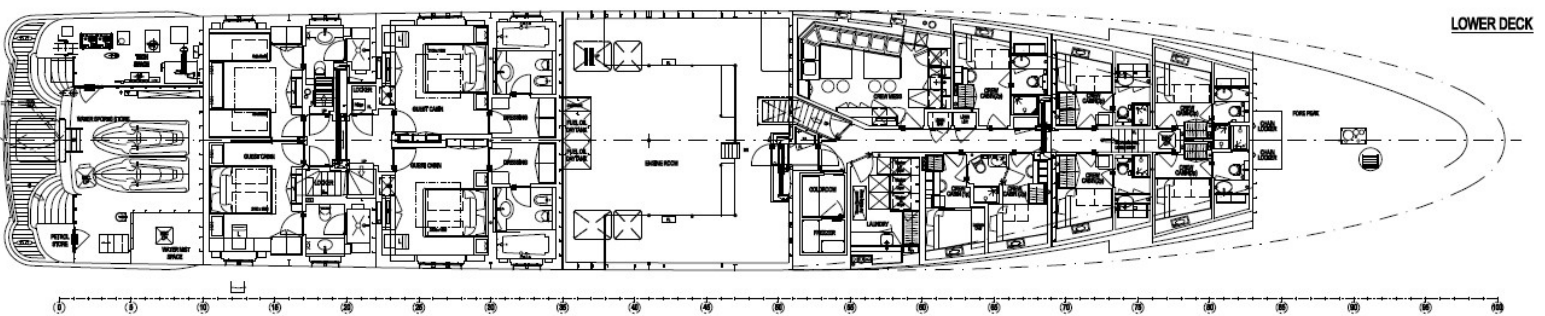
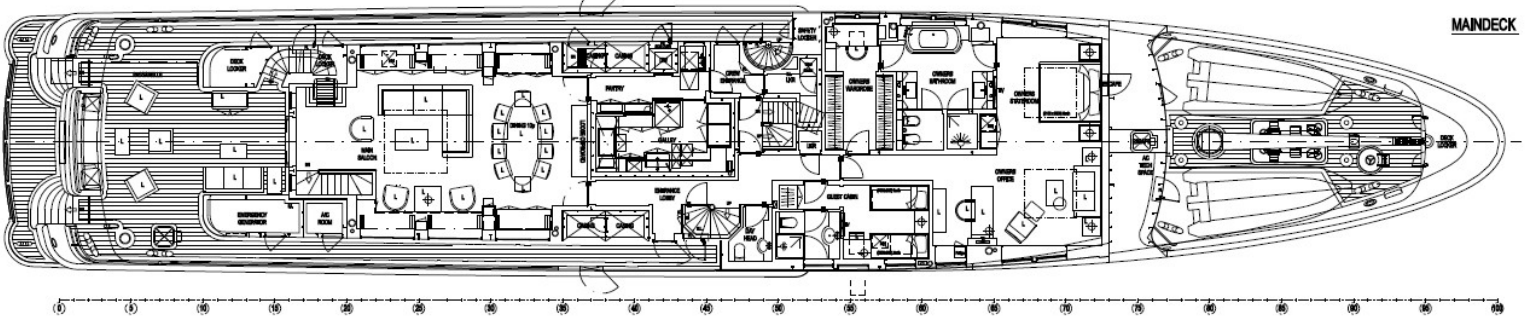
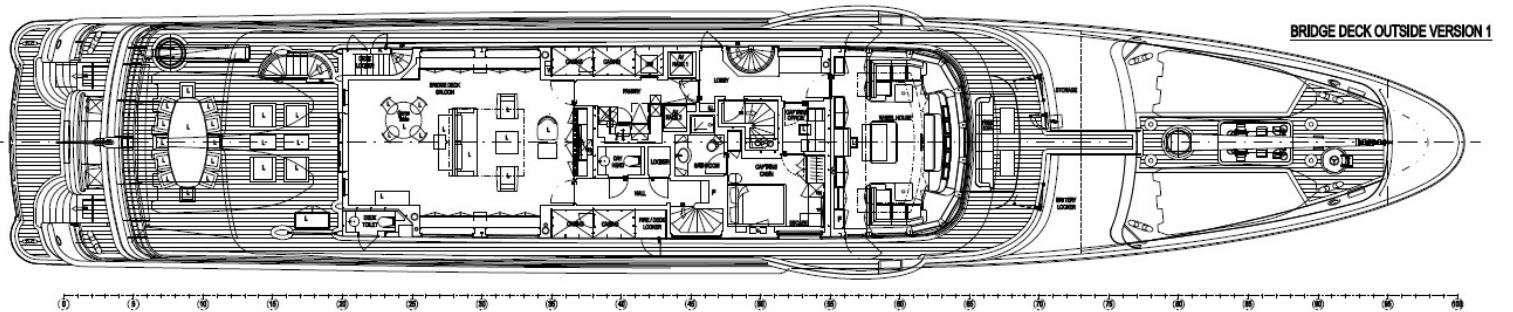
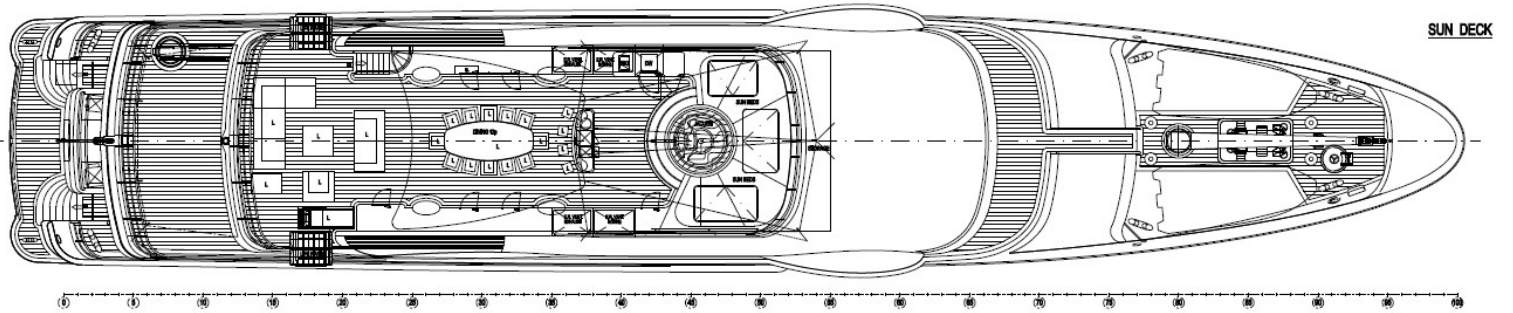

MY GRACE - Specification

PHOTOS



MY GRACE - Specification

PHOTOS

